

Premier Labellers



Premier P200 Labelling System

Premier 200 The Versatile Labelling System

Description

The Premier P200 is a fully automatic front and back and or wrap-around labelling system is designed to handle a wide range of containers and labels with speed and accuracy.

The labelling head can apply front, back, partial wrap or full wrap labels to most shapes of container. The speed of the label head can be adjusted to match customer's production requirements.

The machine is equipped with a non-contact product sensor and optional build back sensor. The user friendly 8 way adjustment on the labelling head ensures that the label is applied precisely onto the container. The twin air controlled nip rollers and stepper motor enable consistent and accurate label positioning at speed.



Container alignment mechanism



Top stabilising belt



After-roll unit for wraparound labels

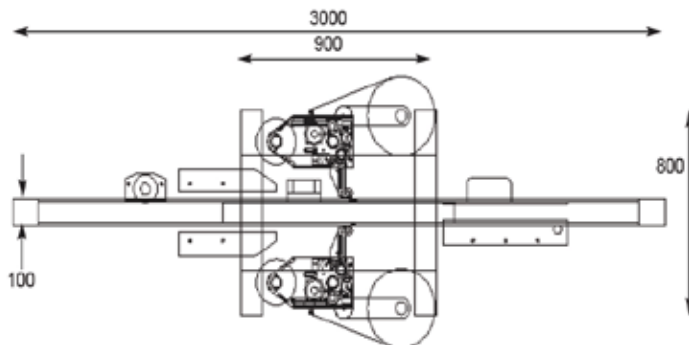

Features

- Modular design
- No change parts required
- 360° LCD Colour touch screen
- Accurate to +/-0.5mm
- Capable of operating upto 350 cpm

Options

- Thermal transfer/hot foil coder
- Variable speed twin pitching mechanism
- After-roll unit for wraparound labels
- Single, twin or quad head units
- Auto-splicing/switching units
- Inspection and rejection systems
- Low reel detector



Premier 200 running at 350cpm at local preserves manufacturer

P200 Applications



The Premier P200 is designed to handle a wide range of containers and labels. The machine's modular construction allows the machine to be entirely versatile, additional container handling components can be added as and when required.

In addition to many standard applications, the P200 is also well equipped to handle difficult applications and environments from harsh chemicals to clean rooms.

Technical Data

Container width/diameter	Upto 150mm
Container height	Upto 300mm
Conveyor width	83mm & 150mm
Label height	150mm/300mm
Max Speed	Upto 350cpm (depending on label size)
Electrical	220/240V single phase 50/60Hz
Compressed air	60/80psi 6 bar (0.0085m/min)



PLF (UK) Ltd, Unit 2 Bathside Bay, Harwich, Essex CO12 3HF

Tel: +44 (0)1255 553822 Fax: +44 (0)1255 241638

sales@premierlabellers.co.uk www.premierlabellers.co.uk