

# Premier Labellers

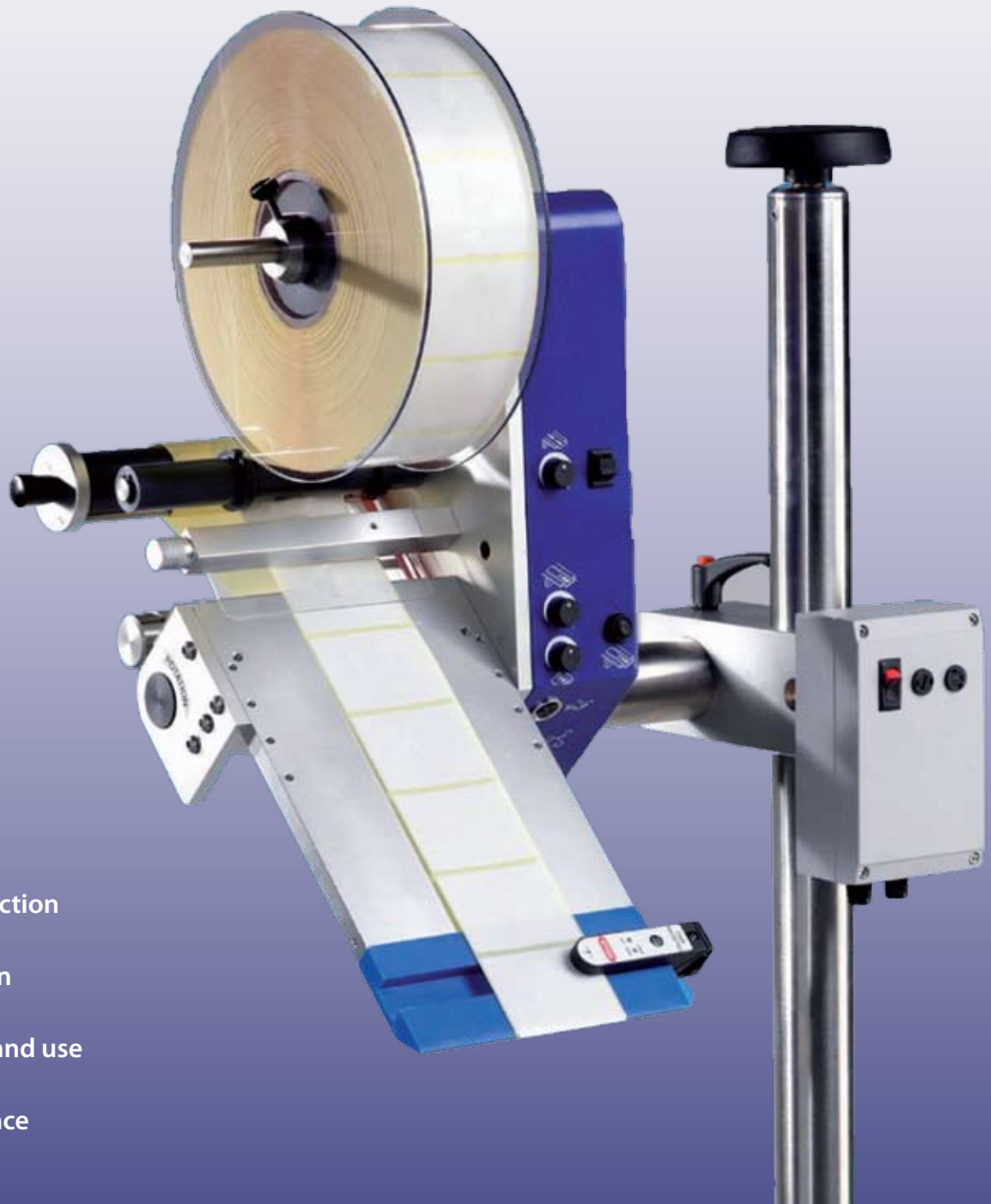

- Robust construction
- Compact design
- Easy to set-up and use
- Low maintenance

**P50 Label Applicator**

# Premier 50 Label Applicator

The Premier 50 has been designed to meet the needs of low volume production or start up operations. Designed as an entry level applicator, the Premier 50 is the latest addition to Premier's extensive range of high quality labelling systems and has been developed in direct response to customer demand for a machine to assist brand owners and contract packers with a simple, low cost solution for product testing and seasonal marketing campaigns.

The Premier 50 is a robust, reliable automatic label head designed to be easily set up and used, with simple label feed path and straightforward, front panel mounted operator controls, for speed and label positioning.

The maximum label size is 150mm wide by 250mm long on rolls up to 250 mm diameter, with operating speeds being between 10 and 20m/min.

The Premier 50 is extremely compact and requires little space to install and operate, enabling the unit to be mounted over an existing conveyor with minimum use of production space.

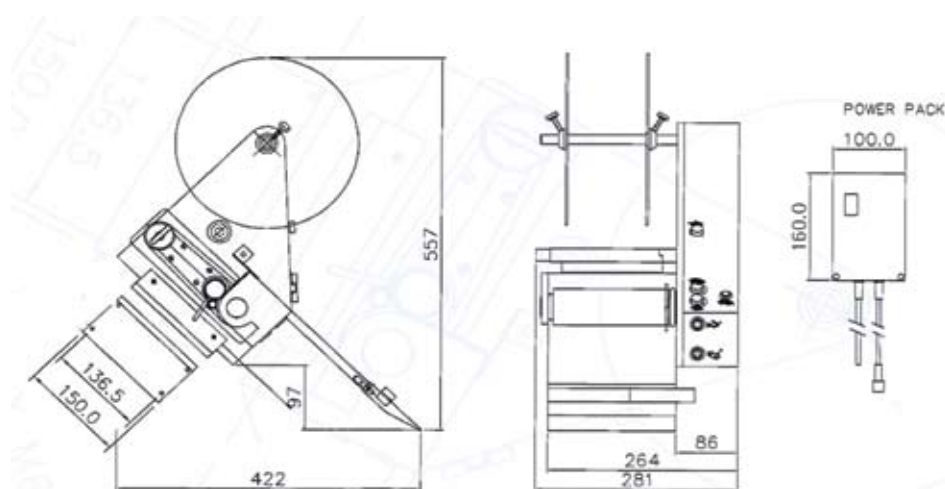

Machine Specifications	
Speed Range	10 - 20 metres/min
Max Label Web Width	150mm
Max Label length	300mm
Label Reel Core Diameter	75mm or 38mm
Production Capacity	10 - 100 products per minute
Electrical Supply	1 phase 230v 50/60Hz
Electrical Consumption	1.5Kw
Weight	12.5Kg

PLF (UK) Ltd  
Unit 2 Bathside Bay  
Harwich  
Essex  
CO12 3HF

Tel: +44 (0)1255 553822 Fax: +44 (0)1255 241638

[www.premierlabellers.co.uk](http://www.premierlabellers.co.uk)

[sales@premierlabellers.co.uk](mailto:sales@premierlabellers.co.uk)